

PEDESTAL SUMP PUMP

MODEL #3CEH, 433063

Español p. 9

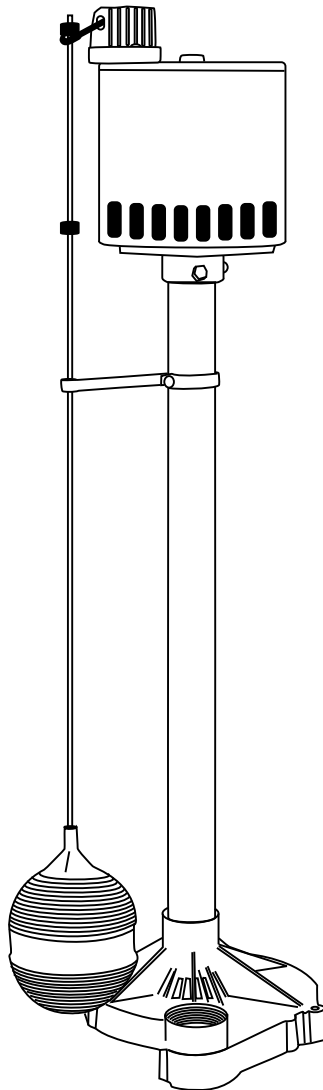

ATTACH YOUR RECEIPT HERE

Serial Number _____ Purchase Date _____

SW1407 C



Questions, problems, missing parts? Before returning to your retailer, call our customer service department at 1-800-742-5044, 7:30 a.m. - 5:00 p.m., EST, Monday - Friday.

PACKAGE CONTENTS

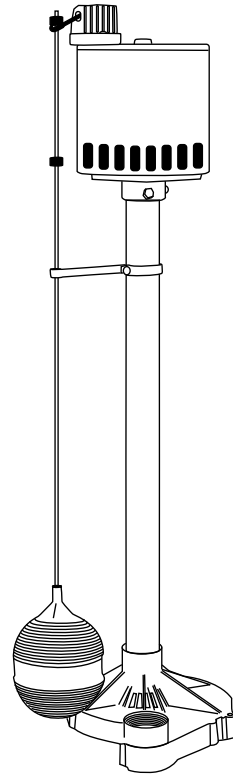

DESCRIPTION	QUANTITY
Pump	1

SAFETY INFORMATION

Please read and understand this entire manual before attempting to assemble, operate, or install the product.

NOTE: Pumps with the “UL” Mark are tested to UL Standard UL778. CSA certified pumps are certified to CSA Standard C22.2 No. 108. (CUS.)

DANGER

- **FIRE/EXPLOSION HAZARD.**
Pump only clear water. Do not pump flammable or explosive fluids such as gasoline, fuel oil, kerosene, etc. Do not use in a flammable and/or explosive atmosphere. Failure to follow these warnings could result in death or serious injury and/or property damage.
- **RISK OF ELECTRIC SHOCK.**
These pumps have not been investigated for use in swimming pool and marine areas.
- **RISK OF ELECTRIC SHOCK.**
Always disconnect power source before attempting to install, service, or maintain the pump. Never handle a pump with wet hands or when standing on wet or damp surface or in water. Fatal electrical shock could occur.
- **RISK OF ELECTRIC SHOCK.**
Keep pump out of reach of children.

WARNING

- **ELECTRICAL SHOCK ALERT.**
Before installing this product, have the electrical circuit checked by an electrician to ensure proper grounding. All electrical installations must conform to the National Electric Code and all local codes.
- **ELECTRICAL SHOCK ALERT.**
Connect this product to a properly-grounded 115 volt circuit equipped with a Ground Fault Circuit Interrupter (GFCI) device. Make sure the electrical supply circuit is equipped with fuses or circuit breakers with a minimum capacity of 15 amps
- **ELECTRICAL SHOCK ALERT.**
Never use an extension cord.
- **ELECTRICAL SHOCK ALERT.**
These pumps are supplied with a 3-prong grounded plug to help protect you against the possibility of electrical shock. DO NOT UNDER ANY CIRCUMSTANCES REMOVE THE GROUND PIN.
- **ELECTRICAL SHOCK ALERT.**
Do not remove or replace the power cord.
- **ELECTRICAL SHOCK ALERT.**
Protect electrical cord from sharp objects, hot surfaces, oil, and chemicals. Avoid kinking the cord.
- **PROP65 WARNING FOR CALIFORNIA RESIDENTS:**
Cancer and Reproductive Harm – www.P65Warnings.ca.go

CAUTION

- **PERSONAL INJURY OR PRODUCT DAMAGE MAY RESULT**
This pump operates on 115 volts. Make certain that the power source conforms to the requirements of your equipment.
- **PRODUCT DAMAGE MAY RESULT**
The continuous operating water temperature for this pump must not exceed 86°F (30°C).
- **PRODUCT DAMAGE MAY RESULT**
This pump is designed to pump water only. It has not been evaluated for pumping chemicals or corrosive materials.
- **PRODUCT DAMAGE MAY RESULT**
Inspect the pump regularly for damage and perform routine maintenance as needed. Remove any debris that may build up around the on/off operation of the float.
- **PROPERTY DAMAGE MAY RESULT**
This product requires a 3/16 in. vent hole to be drilled in the discharge pipe, level with the top of the pump. The vent hole should be checked periodically for clogs. It is normal for water to come out of this vent hole during pump operation.
- **PROPERTY OR PRODUCT DAMAGE MAY RESULT**
This pump is not designed for pumping effluent or sewage.
- **PRODUCT DAMAGE MAY RESULT**
This pump is not designed for continuous operation.

PREPARATION

Estimated Installation Time: 20 minutes

Materials required for assembly: Sump basin, inlet piping, discharge piping (PVC, poly pipe or galvanized steel), check valve, and 2-step PVC glue system (primer and sealer).

MODEL	HP	AMPS	SPECIFICATIONS			
			PERFORMANCE IN GALLONS PER MINUTE			
			0 FT.	5 FT.	10 FT.	15 FT.
3CEH, 433063	1/3	3.5	58	50	36	10

GENERAL PUMP INFORMATION

This pump is designed to be installed in a sump basin for removing clear drain water and will usually pass small particles suspended in water. Heavy mud, sand, or pea gravel can clog the pump, which can usually be cleaned out by back-flushing with a garden hose through the pump discharge.

A check valve must be installed in the discharge pipe to keep water from draining back into the sump basin when it is not operating. The sump basin must be at least 18 in. deep and 12 in. in diameter.

NOTES: Before installing pump:

- Have the electrical circuit checked by an electrician to ensure proper grounding.
- Connect pump to a grounded circuit equipped with a ground fault circuit interruptor (GFCI) device.
- BE CERTAIN the pump power source is disconnected before installing or servicing this unit.
- Be sure the sump basin and piping are clear of sand, dirt and scale. Debris will clog pump and void warranty.
- Failure to protect pump and piping from freezing could cause severe damage and will void the warranty.
- Do not run pump dry.

INSTALLATION INSTRUCTIONS

1. Make sure the sump basin is cleared of any debris or sediment, then place pump (A) on a hard surface inside the basin.

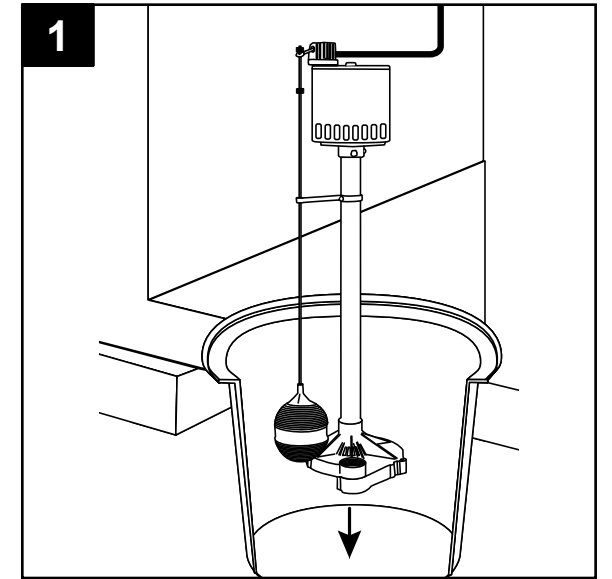

2. Connect the discharge pipe, fittings and check valve (not provided) to pump (A) discharge according to local codes. The discharge pipe should be the same size as the discharge of pump (1-1/4 in.) or larger.

NOTE: Make sure there is enough room in the basin for the float to move freely. If the float is restricted, the pump will not operate.

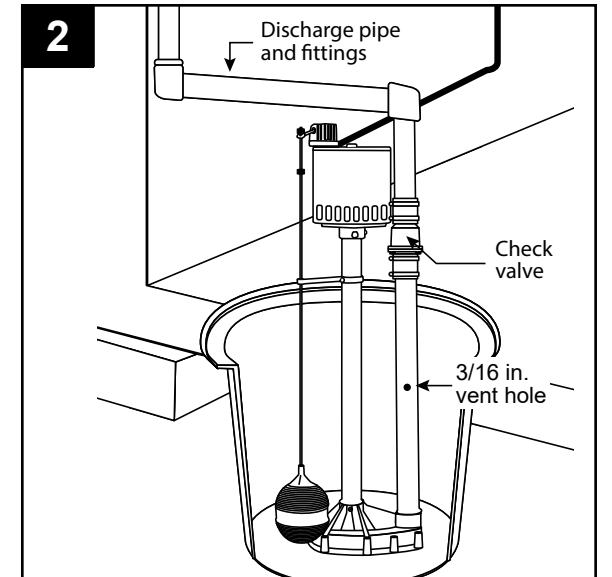

3. Make sure your hands are dry and you are not standing in water. Connect the pump to a properly-grounded, GFCI electrical outlet.

WARNING: Do not use an extension cord.

NOTE: Tape or tie the electrical cord to the discharge pipe to prevent it from interfering with the motion of the float.

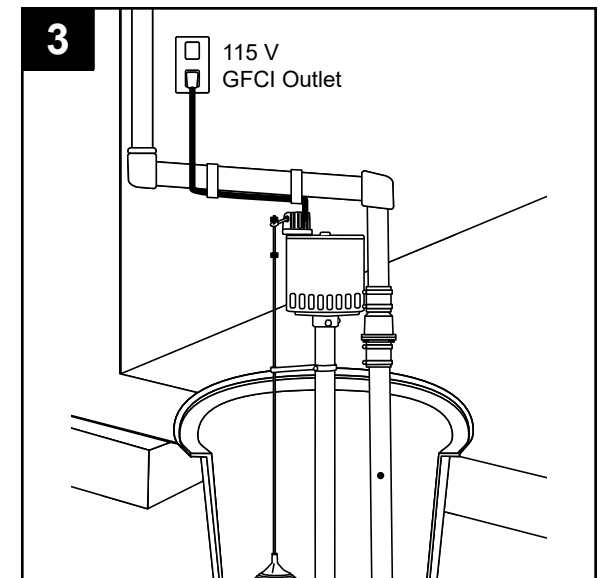

4. Test the operation of the pump by pouring water into the sump basin.

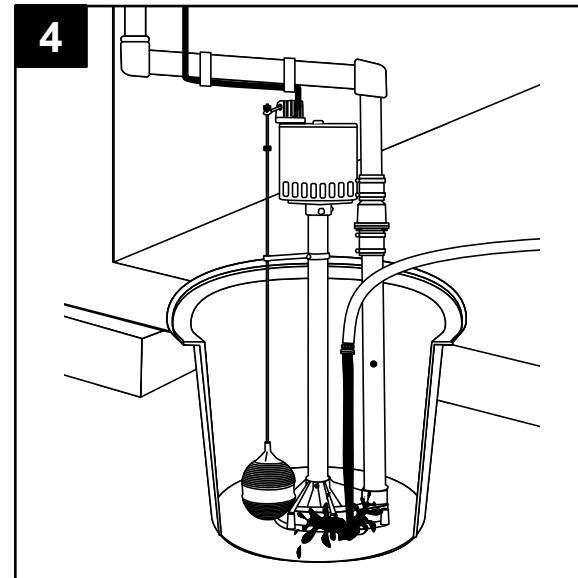

5. If the lower rod stop is positioned 8 in. from the top of the rod, the pump will turn on at approximately 10 in. to 12 in. and off at approximately 2-1/2 in. To cycle the pump on and off faster, move the lower float stop closer to the float rod guide.

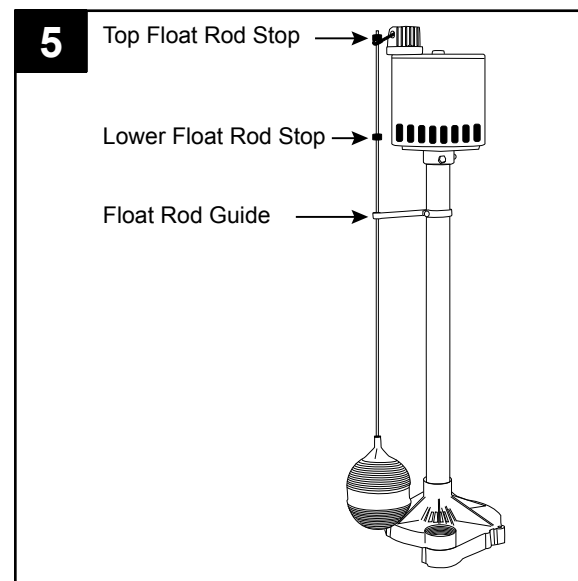

CARE AND MAINTENANCE

WARNING: Always disconnect pump from power source before handling.

At least every three months:

Remove any debris that may build up in the sump basin to prevent it from interfering with the operation of the float switch.

Test system for operation.

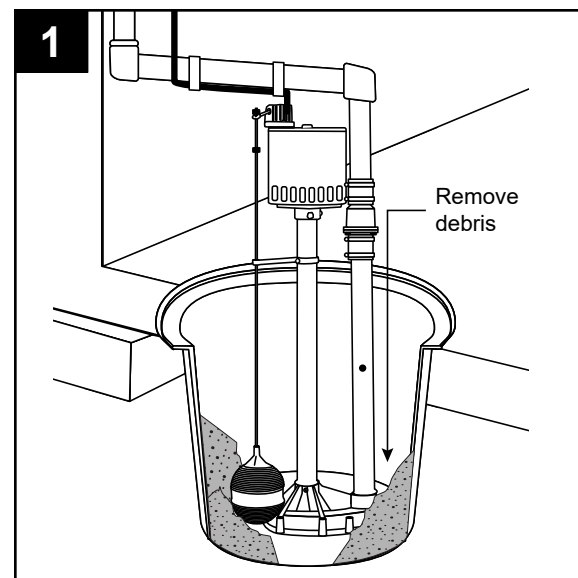

TROUBLESHOOTING

⚠ DANGER
RISK OF ELECTRIC SHOCK.

Always disconnect power source before attempting to install, service, or maintain the pump. Never handle a pump with wet hands or when standing on wet or damp surface or in water. Fatal electrical shock could occur.

PROBLEM	POSSIBLE CAUSE	CORRECTIVE ACTION
Pump will not start or run.	1. Circuit breaker is off or fuse is blown or loose.	1. Reset circuit breaker or replace fuse. If problem continues, contact a professional electrician or plumber.
	2. Water in sump basin is not high enough to cause the switch to turn on.	2. Water will turn on when it reaches the proper level for the pump.
	3. Pump is not plugged in or is connected to a wall switch that has been turned off.	3. Plug pump securely into GFCI outlet that cannot be turned off by a wall switch.
	4. Float cannot move freely.	4. Remove any obstructions around float.
Pump runs but does not deliver water.	1. Make sure check valve is not installed backwards.	1. Arrow on valve should point away from pump.
	2. Shut-off valve (if used) may be closed.	2. Open shut-off valve.
	3. Impeller, pump inlet, or discharge pipe may be clogged.	3. Remove pump from basin and clean impeller, pump inlet, or pipe.
	4. Vertical pumping distance is too high.	4. Reduce the vertical distance to correspond with the performance chart in the instructions.
Pump runs continuously.	1. Float is stuck in the 'on' position.	1. Make sure the float can move freely.
	2. Float switch is defective.	2. Replace float switch.
Pump runs but delivers little water.	1. Vertical pumping distance is too high.	1. Reduce the vertical distance to correspond with the performance chart in the instructions.
	2. Impeller, pump inlet, or discharge pipe may be clogged.	2. Remove pump from basin and clean impeller, pump inlet, or pipe.
Fuse blows or circuit breaker trips when pump starts.	1. Impeller, pump inlet, or discharge pipe may be clogged.	1. Remove pump from basin and clean impeller, pump inlet, or pipe.
	2. Fuse size or circuit breaker may be too small.	2. Electrical circuit capacity must be 15 amps or higher.
Overload trips.	1. Short in motor.	1. Replace pump.
Noisy pump.	1. Worn bearing.	1. Replace pump.

WARRANTY

This product is warranted for one year from the date of purchase. Subject to the conditions hereinafter set forth, the manufacturer will repair or replace to the original consumer, any portion of the product which proves defective due to defective materials or workmanship. This warranty does not cover replacement parts for failure due to normal wear and tear. To obtain warranty service, contact the dealer from whom the product was purchased. The manufacturer retains the sole right and option to determine whether to repair or replace defective equipment, parts or components. Damage due to conditions beyond the control of the manufacturer is not covered by this warranty.

THIS WARRANTY WILL NOT APPLY:

- (a) To defects or malfunctions resulting from failure to properly install, operate or maintain the unit in accordance with printed instructions provided; (b) to failures resulting from abuse, accident or negligence or use of inappropriate chemicals or additives in the water;
- (c) to normal maintenance services and the parts used in connection with such service;
- (d) to units which are not installed in accordance with normal applicable local codes, ordinances and good trade practices; and
- (e) if the unit is used for purposes other than for what it was designed and manufactured.

RETURN OF WARRANTED COMPONENTS:

Any item to be repaired or replaced under this warranty must be returned to the manufacturer at Kendallville, Indiana or such other place as the manufacturer may designate, freight prepaid.

THE WARRANTY PROVIDED HEREIN IS IN LIEU OF ALL OTHER EXPRESS WARRANTIES, AND MAY NOT BE EXTENDED OR MODIFIED BY ANYONE. ANY IMPLIED WARRANTIES SHALL BE LIMITED TO THE PERIOD OF THE LIMITED WARRANTY AND THEREAFTER ALL SUCH IMPLIED WARRANTIES ARE DISCLAIMED AND EXCLUDED. THE MANUFACTURER SHALL NOT, UNDER ANY CIRCUMSTANCES, BE LIABLE FOR INCIDENTAL, CONSEQUENTIAL OR SPECIAL DAMAGES, SUCH AS, BUT NOT LIMITED TO DAMAGE TO, OR LOSS OF, OTHER PROPERTY OR EQUIPMENT, LOSS OF PROFITS, INCONVENIENCE, OR OTHER INCIDENTAL OR CONSEQUENTIAL DAMAGES OF ANY TYPE OR NATURE. THE LIABILITY OF THE MANUFACTURER SHALL NOT EXCEED THE PRICE OF THE PRODUCT UPON WHICH SUCH LIABILITY IS BASED.

This warranty gives you specific legal rights, and you may have other rights which vary from state to state. Some states do not allow limitations on duration of implied warranties or exclusion of incidental or consequential damages, so the above limitations may not apply to you.

In those instances where damages are incurred as a result of an alleged pump failure, the Homeowner must retain possession of the pump for investigation purposes.