

# SUBMERSIBLE UTILITY PUMP

MODEL #UTHALC, 2STHALC, 3STHALC,  
433039, 473685

**Español p. 9**

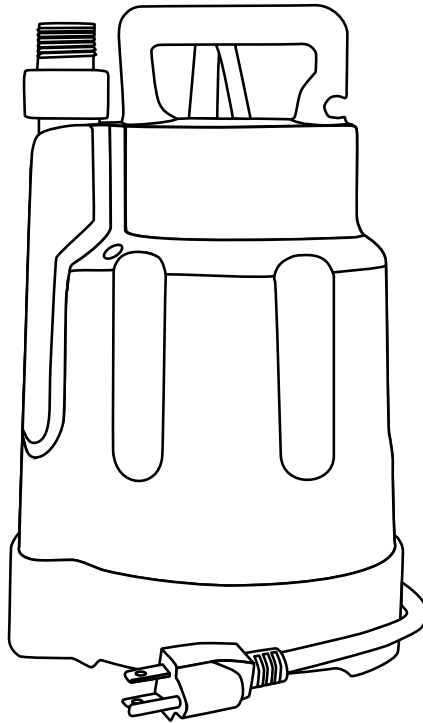

## ATTACH YOUR RECEIPT HERE

Serial Number \_\_\_\_\_ Purchase Date \_\_\_\_\_



Questions, problems, missing parts? Before returning to your retailer, call our customer service department at 1-800-742-5044, 7:30 a.m. - 5:00 p.m., EST, Monday - Friday.

## PACKAGE CONTENTS

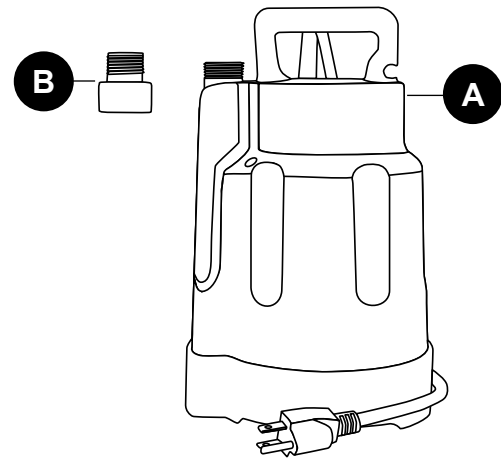

PART	DESCRIPTION	QUANTITY
A	Pump	1
B	Adapter	1

PERFORMANCE							
ITEM NUMBER	HP	AMPS	GALLONS PER MINUTE AT DISCHARGE HEIGHT ABOVE PUMPING LEVEL				
			0 FT.	5 FT.	10 FT.	15 FT.	20 FT.
			UTHALC , 433039	1/6	3.0	25	20
2STHALC, 473685	1/4	3.0	30	24	19	11	-
3STHALC	1/3	4.5	33	29	24	19	13

## SAFETY INFORMATION

Please read and understand this entire manual before attempting to assemble, operate, or install the product.

- **NOTE:** Pumps with the “UL” Mark are tested to UL Standard UL778. CSA certified pumps are certified to CSA Standard C22.2 No. 108. (CUS.)

## DANGER

- **FIRE/EXPLOSION HAZARD.**  
Pump only clear water. Do not pump flammable or explosive fluids such as gasoline, fuel oil, kerosene, etc. Do not use in a flammable and/or explosive atmosphere. Failure to follow these warnings could result in death or serious injury and/or property damage.
- **RISK OF ELECTRIC SHOCK.**  
These pumps have not been investigated for use in swimming pool areas.
- **RISK OF ELECTRIC SHOCK.**  
Always disconnect power source before attempting to install, service, or maintain the pump. Never handle a pump with wet hands or when standing on wet or damp surface or in water. Fatal electrical shock could occur.

## WARNING

- **ELECTRICAL SHOCK ALERT.**  
Before installing this product, have the electrical circuit checked by an electrician to ensure proper grounding. All electrical installations must conform to the National Electric Code and all local codes.
- **ELECTRICAL SHOCK ALERT.**  
Connect this product to a properly-grounded 115 volt circuit equipped with a Ground Fault Circuit Interrupter (GFCI) device.
- **ELECTRICAL SHOCK ALERT.**  
Do not handle pump or pump motor with wet hands or when standing on a wet or damp surface or in water.
- **ELECTRICAL SHOCK ALERT.**  
These pumps are supplied with a 3-prong grounded plug to help protect you against the possibility of electrical shock. DO NOT UNDER ANY CIRCUMSTANCES REMOVE THE GROUND PIN.
- **ELECTRICAL SHOCK ALERT.**  
BE CERTAIN the pump power source is disconnected before installing or servicing pump.
- **ELECTRICAL SHOCK ALERT.**  
Protect electrical cord from sharp objects, hot surfaces, oil and chemicals. Avoid kinking the cord.
- **PERSONAL INJURY ALERT.**  
Provide a means of pressure relief if the pump discharge can be shut off or obstructed. Pumps operating with a closed discharge can create hot liquid, which can cause burns.
- **PERSONAL INJURY ALERT.**  
This pump is equipped with an automatic thermal overload and can restart without warning.
- **PROP65 WARNING FOR CALIFORNIA RESIDENTS:**  
Cancer and Reproductive Harm – [www.P65Warnings.ca.gov](http://www.P65Warnings.ca.gov)

## CAUTION

- **PERSONAL INJURY OR PRODUCT DAMAGE MAY RESULT.**  
Check to be sure your power source is capable of handling the voltage requirements of the motor, as indicated on the pump name plate.
- **PRODUCT DAMAGE MAY RESULT.**  
These pumps are not designed or intended to be used to handle sewage or effluent.
- **PRODUCT DAMAGE MAY RESULT.**  
This pump has been evaluated for use with WATER only.
- **PRODUCT DAMAGE MAY RESULT.**  
Maximum continuous operating water temperature for standard model pumps must not exceed 86°F (30°C).
- **PRODUCT DAMAGE MAY RESULT.**  
Not designed for continuous, ongoing operation. Design life is 4,500 accumulated hours.

## PREPARATION

Before beginning assembly of product, make sure all parts are present. Compare parts with package contents list. If any part is missing or damaged, do not attempt to assemble the product.

**Estimated Assembly Time:** 5 minutes

No Tools Required for Assembly.

## INSTALLATION INSTRUCTIONS

1. Attach garden hose adapter to the pump discharge and then connect garden hose (not included) to adapter. **DO NOT OVERTIGHTEN THE GARDEN HOSE OR HOSE ADAPTER.** Hand tight plus an additional 1/4 to 1/2 turn should be sufficient.

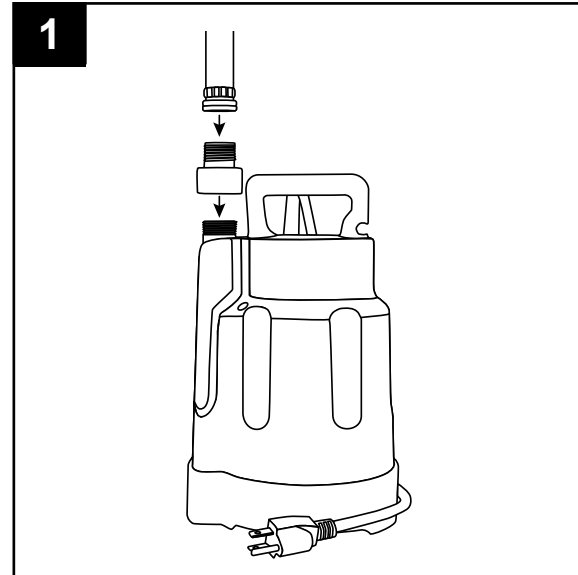

2. Place pump in the water on a hard surface. Pump will operate continuously whether partially or fully submerged. Avoid placing pump directly on sand, dirt, or mud.

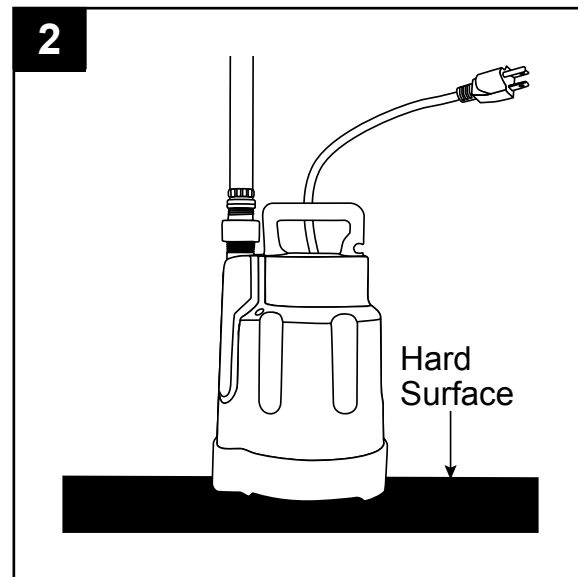

3. Plug pump into a properly grounded 115 V AC power outlet.

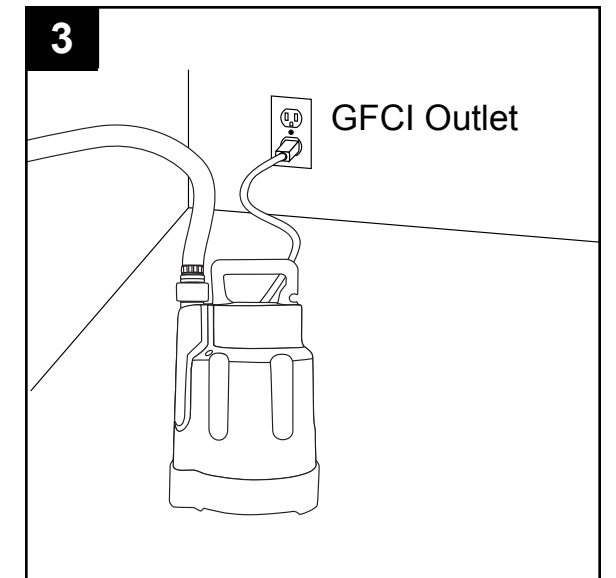

4. Pump has an air valve to prevent air-locking. Air-locking will keep pump from pumping water. A small spray of water from the air valve is normal and does not represent a defective pump.

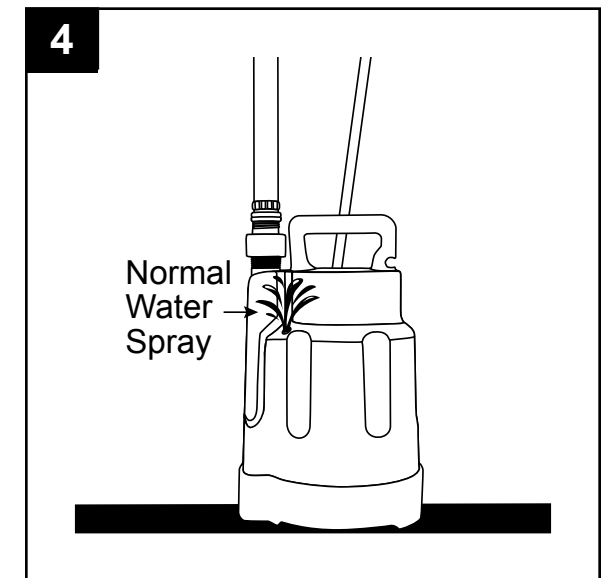

## OPERATING INSTRUCTIONS

1. When the water level at bottom of pump drops to approximately 3/16 in., pump will continue to run but will stop moving water. Unplug pump when water stops flowing from the hose.

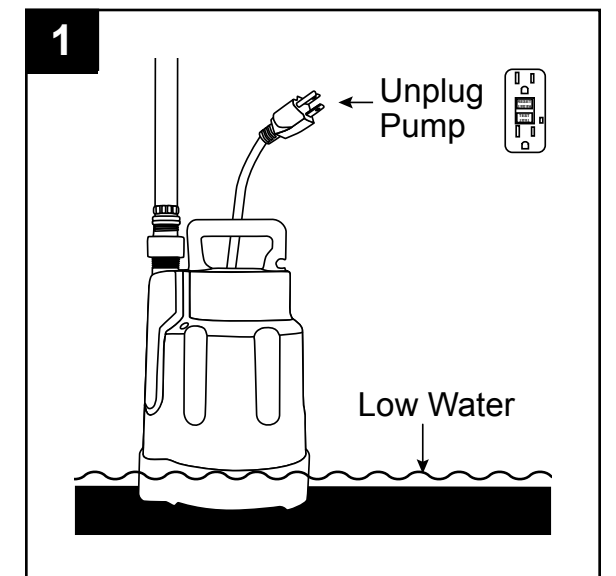

- DO NOT RUN DRY. Running pump when it is not submerged in water will damage the seal and impeller, and void the warranty.

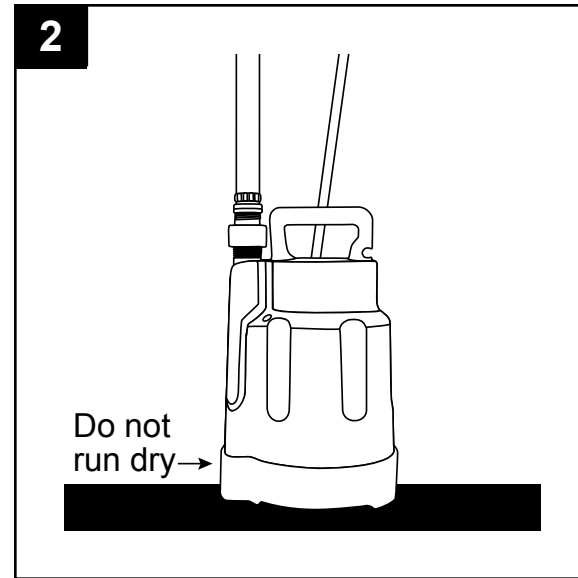

### CARE AND MAINTENANCE

The motor housing of pump is completely sealed and requires no service. Disassembly of the motor housing or alteration of the power cord voids all warranty.

- Periodically unplug pump to inspect the inlet and remove any debris. Make sure your hands are dry and that you are not standing in water.

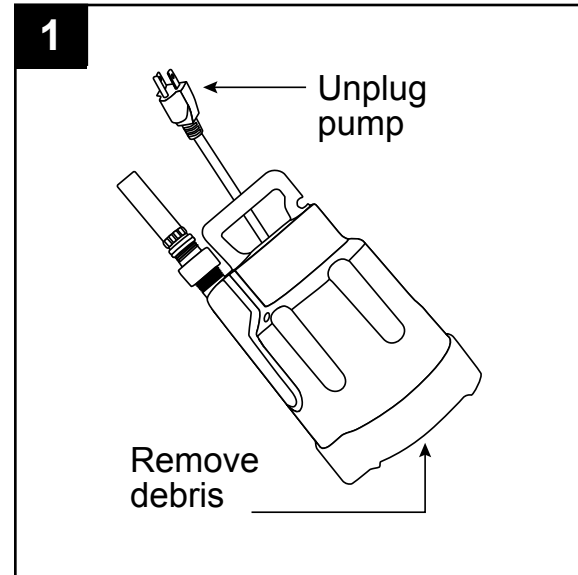

- If pump clogs, unplug the pump from the power supply. Attach one end of a garden hose to a spigot and the other end to pump discharge. Turn on the spigot to run water through pump to clean it out.

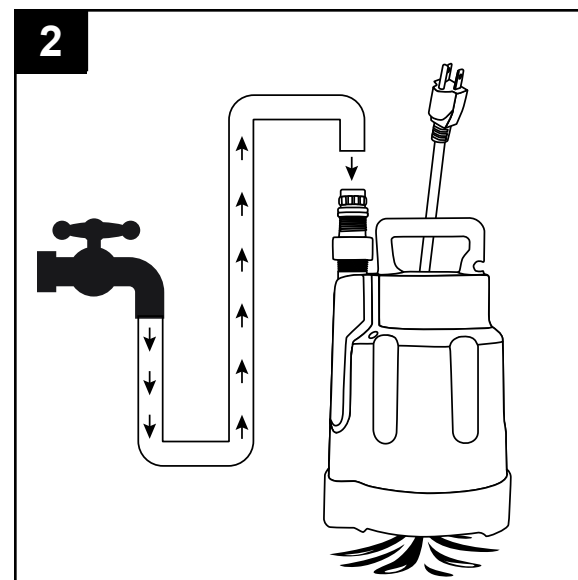

### TROUBLESHOOTING

PROBLEM	POSSIBLE CAUSE	CORRECTIVE ACTION
Pump runs, but no water is discharged.	1. Hose kinked.	1. Straighten hose.
	2. Defective pump.	2. Replace pump.
	3. Discharge height too great.	3. Reduce discharge height.
	4. Clogged inlet.	4. Clean inlet.
Motor runs too hot.	1. Voltage incorrect.	1. Connect to 115 volt outlet.
	2. Restricted discharge hose.	2. Increase hose diameter to 3/4 in.
	3. Pump damaged.	3. Replace pump.
	4. Plugged or kinked discharge.	4. Clean and straighten hose.
Flow rate is low.	1. Hose kinked.	1. Straighten hose.
	2. Clogged impeller.	2. Clear obstruction.
	3. Excessive length of hose.	3. Reduce length of outlet hose.
Pump will not run.	1. No power.	1. Verify that unit is plugged into 115 volt outlet.
	2. Motor overheated.	2. Motor has automatic thermal protector. Wait 15 minutes for motor to cool.

## **WARRANTY**

---

This product is warranted for one year from the date of purchase. Subject to the conditions hereinafter set forth, the manufacturer will repair or replace to the original consumer, any portion of the product which proves defective due to defective materials or workmanship. This warranty does not cover replacement parts for failure due to normal wear and tear. To obtain warranty service, contact the dealer from whom the product was purchased. The manufacturer retains the sole right and option to determine whether to repair or replace defective equipment, parts or components. Damage due to conditions beyond the control of the manufacturer is not covered by this warranty.

### **THIS WARRANTY WILL NOT APPLY:**

- (a) To defects or malfunctions resulting from failure to properly install, operate or maintain the unit in accordance with printed instructions provided;
- (b) to failures resulting from abuse, accident or negligence or use of inappropriate chemicals or additives in the water;
- (c) to normal maintenance services and the parts used in connection with such service;
- (d) to units which are not installed in accordance with normal applicable local codes, ordinances and good trade practices; and
- (e) if the unit is used for purposes other than for what it was designed and manufactured.

### **RETURN OF WARRANTED COMPONENTS:**

Any item to be repaired or replaced under this warranty must be returned to the manufacturer at Kendallville, Indiana or such other place as the manufacturer may designate, freight prepaid.

THE WARRANTY PROVIDED HEREIN IS IN LIEU OF ALL OTHER EXPRESS WARRANTIES, AND MAY NOT BE EXTENDED OR MODIFIED BY ANYONE. ANY IMPLIED WARRANTIES SHALL BE LIMITED TO THE PERIOD OF THE LIMITED WARRANTY AND THEREAFTER ALL SUCH IMPLIED WARRANTIES ARE DISCLAIMED AND EXCLUDED. THE MANUFACTURER SHALL NOT, UNDER ANY CIRCUMSTANCES, BE LIABLE FOR INCIDENTAL, CONSEQUENTIAL OR SPECIAL DAMAGES, SUCH AS, BUT NOT LIMITED TO DAMAGE TO, OR LOSS OF, OTHER PROPERTY OR EQUIPMENT, LOSS OF PROFITS, INCONVENIENCE, OR OTHER INCIDENTAL OR CONSEQUENTIAL DAMAGES OF ANY TYPE OR NATURE. THE LIABILITY OF THE MANUFACTURER SHALL NOT EXCEED THE PRICE OF THE PRODUCT UPON WHICH SUCH LIABILITY IS BASED.

This warranty gives you specific legal rights, and you may have other rights which vary from state to state. Some states do not allow limitations on duration of implied warranties or exclusion of incidental or consequential damages, so the above limitations may not apply to you.

**In those instances where damages are incurred as a result of an alleged pump failure, the Homeowner must retain possession of the pump for investigation purposes.**